

INSTALLATION INSTRUCTIONS FOR TITAN HYBRID PLANKS. IN ORDER TO OBTAIN A GOOD RESULT, WE ADVISE TO FOLLOW ALL GIVEN INSTRUCTIONS CAREFULLY.

PREPARATION

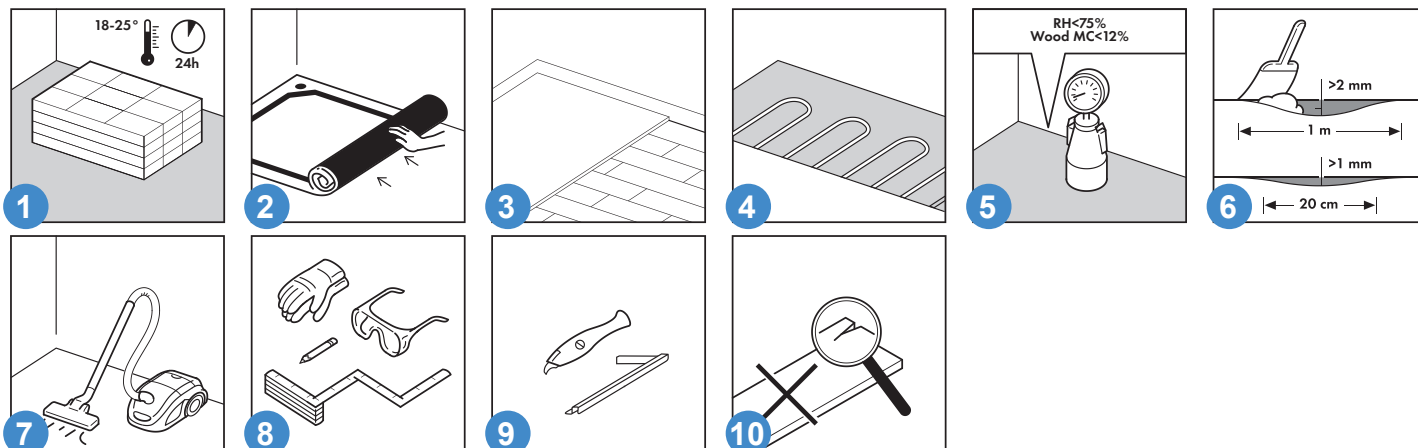

1. **Important Information: It is important to employ safe working practices when cutting or fitting floor coverings. Protective eyewear and safe footwear (steel capped preferably) should be worn throughout the installation to help prevent against injury. Dust extraction and respiratory protection (appropriate dust masks) should be used when cutting flooring or trims using a saw of any type. Materials Safety Data Sheets are available by contacting your local Premium Floors or Floorscape branch. If using ancillary products like levelling compounds etc, it is recommended to adhere to the specific safety requirements as stated by the manufacturer of the product.**
2. It is a good idea to bring the packs to room temperature prior to installation, by having them in the room prior. Particularly, packs that have been stored in cold or hot locations should be left in the room for up to 24 hours between 18-25°C prior to installation, so that they can closely approximate to this room temperature.
3. Remove any damp-porous floor covering (carpet, needle felt, etc.) first. Hard floor covering of PVC, linoleum, ceramic tiles, etc. does not have to be removed.
4. Wooden subfloor: Remove any existing floor covering first. No signs of mold and/or insect infestations should be present. Make sure the subfloor is level. Nail down any loose parts. Titan Hybrid can be directly installed over flat wooden subfloors, however unevenness greater than 2 mm/1 m should be sanded, leveled or sheeted with a suitable wood-based underlay to render them flat and stable. The crawl space under the sub-floor must be sufficiently ventilated. Remove any obstacles and make sure there is sufficient ventilation. The moisture content of the wood must not exceed 12%.
5. Additional instructions apply if there is underfloor heating or cooling. Your dealer or installer of the floor heating system must guarantee that the floor surface temperature never exceeds 28°C. Only in-slab heating systems are suitable, always install a 200um plastic barrier before installing, and bring up temperature 5°C per day after install.
6. The moisture content of any concrete sub-floor must be less than 80%rh when tested in accordance with AS1884-2021. If you do not have the ability to accurately test the moisture content, or if the content is above 80%rh, a continuous damp-proof should be installed. The easiest way to install this damp-proof is by the installation of a PE plastic film of 150um thickness or greater. Joints should be overlapped 300mm and taped. Other types of 'coat on' damp proofs can be used, as long as they are compatible with the moisture content of your sub-floor. Wood sub-floors must be below 14%MC, otherwise a separate damp-proof should again be installed. Failure to follow the procedure regarding sub-floor moisture, can lead to a floor failure.
7. Make sure the subfloor is level. Any unevenness greater than 2 mm over the length of 1 meter must be smoothed out. The same applies to any unevenness of more than 1 mm over a length of 20 cm. Grout lines wider than 3mm and deeper than 2mm should be filled.
8. Make sure that the floor base is flat, clean, firm and dry.
9. To install your Titan Hybrid floor, you need the following standard tools: hammer, jigsaw, pencil, tape measure, safety goggles and gloves.
10. Apart from that, you also need the following accessories: installation kit (a pulling iron, spacers and a tapping block suitable for the Uniclic® click system), and suitable maintenance products. Always use only the recommended accessories for best results.
11. Check all panels before and during installation. Defective or damaged panels must never be used.
12. Check whether the old skirting can be removed. You can leave the wall skirting boards in place and finish the floor with a matching scotia.
13. Check that the doors can still open and close after the floor has been installed. Undercut doors as necessary.
14. Island benches, kitchens and other very heavy objects should be installed first and not placed on top of the flooring. The rigid floor must be able to expand and contract with changes in temperature.

INSTALLATION

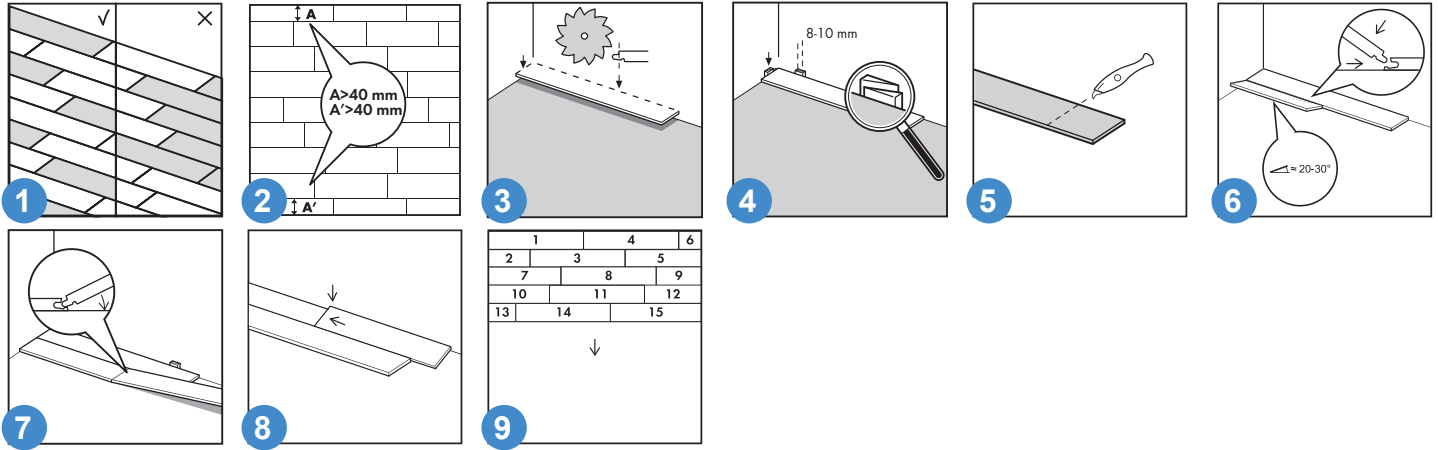

Titan Hybrid planks click to each other using the Uniclic® joining system, over a properly prepared subfloor, they are not fixed to the subfloor. Because vinyl grows or shrinks with temperature change it is necessary to leave a gap around the entire perimeter. It is important to condition and install the flooring at the approximate service temperature (18-25°C) to prevent excessive growth or contraction during periods of high and low temperature. Most open plan areas can be installed without need for control joints, however it is a good idea to install control joints at doorways to allow the entire panel to expand or contract freely. This is called “compartmentalisation”. A perimeter gap of 10 mm is recommended, this will be covered with skirting, scotia or other special profiles available from your retailer. Be aware that if the flooring is installed at a higher temperature, it is likely to contract during cold periods, as such a **cover** of 5-8 mm will be required. Similarly, when installed at low temperature, the floor is likely to expand during hot periods, as such a full **gap** of 10 mm will be required. In general, continuous runs of flooring should not exceed 15 m in a residential home. However, continuous runs may well exceed this in areas subject to continuous temperature control eg office space.

With the Uniclic® joining system you can choose where you want to begin. Think about what the easiest way will be to install the floor. We will demonstrate the installation for right-handed people, from left to right. You can work in the other direction if you want. Uniclic® is unique because you can install the planks in two different ways:

Method A: Position the panel to be installed at an angle of 20 to 30° to the panel already installed. Move the panel gently up and down and at the same time exert forward pressure. The panels will automatically click into place. You can either insert the tongue into the groove, or the groove on to the tongue. The tongue in groove method is the most common and easiest way.

Method B: With Uniclic® you can also tap the panels into each other without lifting. For this method you must use the special Uniclic® tapping block. The planks should not be joined with a single tap. To avoid damaging the panels you must tap them together gradually.

1. Make sure the panels are mixed sufficiently when you install them, so that you do not end up with too many identical, light or dark panels next to each other. To obtain the best visual effect, it is best to fit the floorboards in the direction of the longest wall and parallel to the incidence of light.

2. Before starting, carefully measure the length and the width of the room to plan a precise layout to achieve a balanced appearance of the floor. This will also ensure that you won't end up with the last row being too narrow. If the last row would be less than 40 mm, the installation will be easier if you cut down the planks of the first row in the length.
3. Begin the first row with a whole plank. First saw off the tongue on both the long and the short sides.
4. Put the plank with sawn off sides against the wall. Put spacers from the installation kit between the planks and the wall. This will ensure that your expansion joint is wide enough: 8 to 10 mm.
5. Of course, we also need to saw the panels. To obtain a clean cut, the pattern side should face down when you use a jigsaw. Ensure that the end joints of the panels in two successive rows are never in line. Always ensure that the joints are staggered by at least 30 cm.
6. Position the panel to be installed at an angle of 20 to 30° to the panel already installed. Move the panel gently up and down and at the same time exert forward pressure. The panels will automatically click into place.
7. With Uniclic® you can also tap the panels into each other without lifting. For this method you must use the special Uniclic® tapping block. The planks should not be joined with a single tap. To avoid damaging the panels you must tap them together gradually.
8. In places where it is too difficult to install the Uniclic® planks with the tapping block (e.g. against the wall), you can tap them together using the pulling iron and a hammer.
9. Once enough rows are installed, it is easy to continue the installation as follows: Put an unopened pack of panels on the already installed rows. Switch your position and click the short side of the panel in the previous panel.
10. Now place your BOTH hands close to the joint and pull the long side of the plank towards you. The panels will now click together.
11. Continue like this to the end of the room.
12. Remember that Titan Hybrid flooring expands when heated and contracts when cooled. As such a gap is left around the entire perimeter and between the floor and any vertical object. It is also a good idea to install a control joint at any doorways to allow the panels to expand and contract freely, without affecting the adjoining area, this is called ‘compartmentalisation’.
13. Remove all spacers.

FINISHING

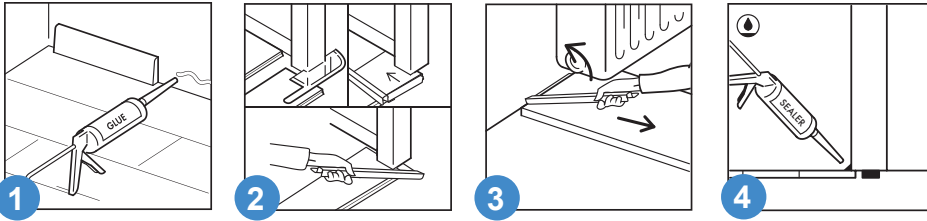

1. Install the skirting-board against the wall. Never attach the skirting-board or scotias to the floor. This method allows the floor to expand and contract under the skirting-board. In places where profiles, skirting-boards or scotias cannot be placed, fill expansion joints with a non-hardening filler.
2. When sawing the panels make sure that the expansion joint under the door is at least 10 mm. If you cannot lift the panel, use the tapping block or pulling iron and hammer to tap the panels together when the planks are flat on the floor.
3. In places where it is difficult to install the planks with the tapping block (e.g. underneath radiators), you can tap them together with the pulling iron and a hammer.

FINISHING IN ROOMS LIKE BATHROOMS, KITCHENS, LAUNDRY ROOMS AND ENTRANCE AREAS

4. We recommend the sealing of the floor perimeter in bathrooms, laundries or other areas prone to have excessive amounts of water on the floor. This is to prevent water flowing in and under the floor at the perimeter. Sealing of the perimeter in such wet areas can be completed with a soft silicon.

MAINTENANCE

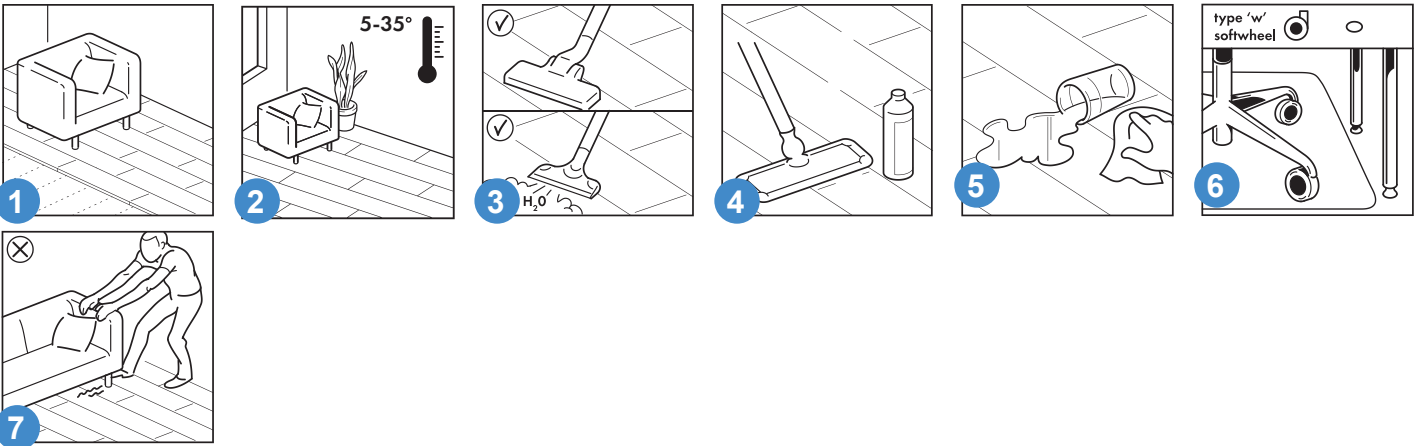

1. You can immediately walk on your new Titan Hybrid floor after installation.
2. You can walk on the floor during and immediately after installation. Ensure that temperature in the room is always above 5°C and below 35°C.
3. For dry maintenance, we advise a soft broom or vacuum cleaner. Make sure the vacuum cleaner is equipped with soft wheels and a special parquet brush to avoid scratches on your floor. It is important to understand that steam mops or wet mops are not recommended for any hard surface floor covering. Steam cleaners and wet mops however are permitted on Titan Hybrid. If using a steam cleaner, please ensure that a cloth covers the direct steam pressure on any device as this will help an even distribution of steam and heat. Keep the steam cleaner moving during cleaning and, for best results, clean the floor in the same direction as the planks have been installed.
4. For slightly damp and wet maintenance, we advise to use the recommended cleaning and maintenance kit. Be aware that the use of other cleaning products might damage your floor.
5. General spot cleaners are suitable for removal of most marks. Wipe up spills and stains as quickly as possible.
6. Protect furniture and chair legs. Avoid bringing dirt, water and sand indoors by providing a suitable floor mat at the door. Use (office) chairs and seats with soft wheels that are suitable for hard floors and/or use a suitable desk mat.
7. Never drag items of furniture over the floor but lift them up.
8. The smooth surface of your Titan Hybrid floor will not retain dirt or dust. Remove stubborn stains carefully with a citrus based cleaner or eucalyptus oil. Never use scouring products! Never use wax or varnish coating on the floor.